

Evaluation of Irrigation Valve Boxes as Underground Bait Stations for California Ground Squirrel Control

Tracy Ellis, Terrell P. Salmon and Cheryl Wilen

University of California Cooperative Extension, San Diego County, San Diego, California

ABSTRACT: The anticoagulants chlorophacinone and diphacinone are registered in California to control ground squirrels. Since multiple feedings on these anticoagulants are necessary, bait stations are often used. Several bait station designs have been suggested and used to reduce tampering and also to minimize bait exposure to non-target animals. Potential options to reduced exposure risk strategies are to use a modified-T bait station, underground bait station, or in-burrow baiting. This study evaluated the behavior of ground squirrels with regard to modified-T and underground bait station compared to the standard-T bait station that is commonly used for ground squirrel control.

KEY WORDS: bait stations, baiting strategies, behavior, burrows, California ground squirrel, food habits, rodent control, *Spermophilus beecheyi*, surveillance, underground bait stations, video

Proc. 22nd Vertebr. Pest Conf. (R. M. Timm and J. M. O'Brien, Eds.)
Published at Univ. of Calif., Davis. 2006. Pp. 148-150.

INTRODUCTION

The California ground squirrel *Spermophilus beecheyi* is indigenous to the oak-savannah grasslands. Historically, squirrel competition for food and their extensive burrows created conflict with cattle grazing. Ground squirrels also inhabit agricultural and other developed land and are destructive to many crops, especially fruit and nut, orchards, irrigation systems, and other structures (Marsh 1978, 1998). Ground squirrel burrows are especially troublesome because they cause soil erosion (Longhurst 1957) and damage aqueducts and levees. Squirrels often inhabit recreational and picnic areas where they are the host for the plague-infected flea life cycle, which puts visitors at risk for this deadly disease (Salmon 1981, Marsh 1982, Bizanov and Dobrokhlova, 2006).

The anticoagulants chlorophacinone and diphacinone are registered in California to control ground squirrels. They are applied by agricultural operations, vector control agencies, and others to control ground squirrels causing agricultural and structural damage or posing public health risks. Anticoagulants are vitamin K antagonists that affect enzymes necessary for forming blood clotting factors. This leads to symptoms of capillary damage and internal hemorrhaging (Tasheva 1995, Ware 2000). Generally, feeding on anticoagulants over several days is required for the bait to be effective.

Supplying continuous access to anticoagulant baits can be done by placing bait in a bait dispenser, i.e. bait station. The aboveground standard-T bait station (Figure 1) is the most common station used for California ground squirrel control (Salmon 1981, Marsh 1994). Unfortunately, these stations can become a target of tampering when used in public areas. This can lead to spilled bait, which is a hazard to dogs, domesticated animals, birds, and other wildlife. And, a destroyed bait station means the control program is no longer effective.

Several bait station designs have been suggested and used to reduce tampering and also to minimize bait exposure to non-target animals. For example, to prevent use by endangered kangaroo rat and kit fox, a modified-T bait station (Figure 2) was developed and is now accepted

for use in the range of these endangered species (Whisson 1999). An underground bait station has been described that would camouflage it from public view (Marsh 1995). This station uses a buried irrigation valve box with two 1 to 2-m- (3 to 6-ft-)-long, 7.5 to 10-cm-diameter (3 to 4-in) corrugated flexible drain pipes attached (Figure 3). The valve box and drain pipes are set underground and buried, with the lid of the valve box and the ends of the drain pipes exposed at the soil level. The station is serviced through the lid by placing the bait in a bowl or tray at the bottom of the valve box. Since this is sitting on soil, a layer of gravel can be used to reduce moisture exposure.

Little data are available on actual use of bait stations by squirrels. In testing the modified or standard T bait stations, squirrels began to use them from 1 to 6 days after they were placed in the environment (Whisson 1999). Little or no work has been reported on squirrel use of other kinds of bait stations. This report describes and compares ground squirrel use of standard-T, modified-T, and underground bait stations.

METHODS

Choice-Test between Bait Station Types

A ground squirrel colony of approximately 279 m² (3,000 ft²) was selected in an oak grassland area among rock outcroppings and oak trees in Valley Center, California. Bait stations of each type were tested: standard-T (as described by Salmon 1981), modified-T (as described by Whisson 1999), and underground bait (as described by Marsh 1995). In August 2005, 4 stations of each type were filled with untreated oats and observed by measuring oat consumption for a 12-day period. The stations remained in the field but were not baited. In October, the same stations were serviced with 0.005% chlorophacinone oat bait and observed for 9 days or until feeding stopped.

Underground Bait Station Use

To gain additional insight into the use of underground bait stations, another test was setup in a 0.8-hectare (2-acre) area in Valley Center, California. At this site,

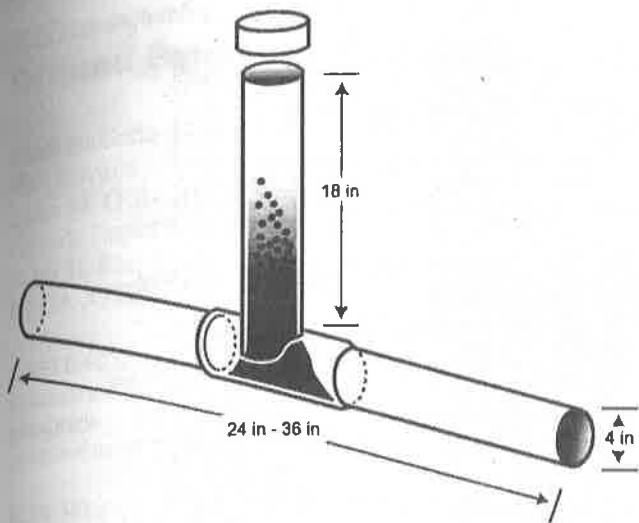

Figure 1. Aboveground standard-T bait station, constructed of PVC pipe.

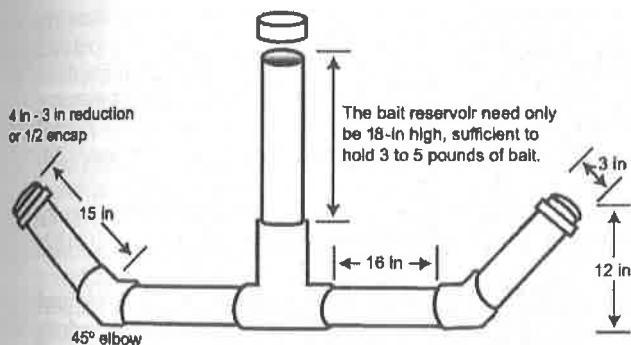

Figure 2. Modified-T bait station, used to prevent entry by certain endangered species.

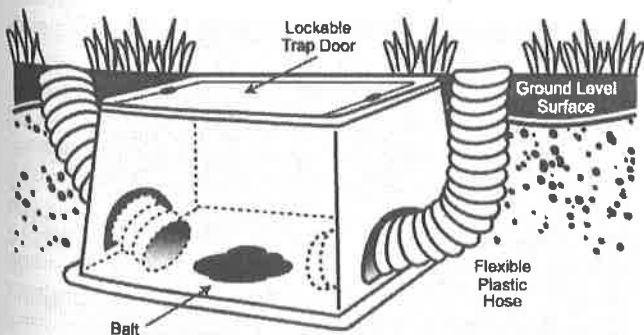

Figure 3. Underground bait station, made with a typical buried irrigation valve box and corrugated drain pipe.

squirrel burrows were associated with rock outcroppings in and adjacent to a dryland oat field. Underground bait stations and modified-T bait stations were set in pairs and observed using oat consumption. Squirrel use was also monitored in the underground bait stations using the Quad Sentinel Video System (Sandpiper Technologies, Manteca, CA). The timing and duration of the squirrel visitation in the underground station was determined from video recordings.

RESULTS

Choice-Test

During the initial exposure period, ground squirrels visited the standard-T bait stations and underground bait stations 5 to 7 days after placement, compared to 9 to 12 days for the modified-T bait station (Table 1). All 4 of the standard-T bait stations, 2 of the undergrounds, and 3 of the modified-T bait stations were visited during the 12-day test period. One of the modified-T bait stations was never visited during the course of the study. During the 12-day study, the total amount of oats consumed was greatest for the standard-T bait stations (13.6 kg; 30 lbs), followed by the underground stations (11.3 kg; 25 lbs). The modified-T bait had the least amount of oats consumed (2.7 kg; 6 lbs) during the 12-day study (Table 1).

Two months after the initial 12-day test, chlorphacinone-treated oats were placed in the bait stations. All 3 bait station types were visited by Day 3. On Day 5, squirrels stopped visiting the modified-T bait station. By Day 9, no bait was being consumed at any station (Table 2). During the course of the test with chlorphacinone-treated oats, the greatest consumption occurred from the standard-T bait station at 4.7 kg (10.5 lbs), while the underground bait station had 3.9 kg (8.7 lbs.) and the modified-T bait station had 1.2 kg (2.6 lbs) taken (Table 2).

Underground Bait Station Use

Total consumption of clean oats during July-September at underground compared to modified-T bait stations was almost equal over time at 65.3 kg (144 lbs) and 69.4 kg (153 lbs) respectively. The average length of visits to the underground stations peaked between 12 PM and 4 PM at 1.5-1.6 minutes per visit. The most activity at the bait station in terms of total number of visits to the bait station occurred between 10 AM and 3 PM. An overall increase in the total time spent each day in 4 underground bait stations occurred during the course of the study, maximum being 468 minutes.

DISCUSSION

California ground squirrels used all 3 bait station types although there were differences in visitation and overall use. Squirrels did not accept the modified-T bait station as quickly as the other 2 types of bait stations; however, once conditioned, the squirrels took bait readily from all station types. This suggests there may be a longer acceptance interval when using other types of bait stations compared to the standard-T bait station, but eventually, the stations will be used. When offered a choice, the squirrels consumed 4-5 times more bait from the

Table 1. Total consumption of clean oats from standard-T bait, modified-T bait, and underground bait stations when California ground squirrels were offered a choice.

| | Total rolled oats consumed (kg) | | | | | | | Total |
|--------------------------|---------------------------------|--------|--------|--------|--------|--------|--------|-------|
| | N | 10-Aug | 12-Aug | 15-Aug | 17-Aug | 19-Aug | 22-Aug | |
| Standard-T bait Station | 4 | setup | 0 | 0 | 4.5 | 4.5 | 4.5 | 13.6 |
| Modified-T bait Station | 4 | setup | 0 | 0 | 0 | 0 | 2.7 | 2.7 |
| Underground bait Station | 4 | setup | 0 | 0 | 2.3 | 4.5 | 4.5 | 11.3 |

Table 2. Total consumption of 0.005% chlorophacinone-treated oats from standard-T bait, modified-T bait, and underground bait stations when California ground squirrels were offered a choice.

| | Total 0.005% chlorophacinone-treated oats consumed (kg) | | | | | | | Total |
|--------------------------|---|--------|-------|-------|--------|--------|--------|-------|
| | N | 05-Oct | 7-Oct | 8-Oct | 10-Oct | 11-Oct | 14-Oct | |
| Standard-T bait Station | 4 | setup | 0.4 | 0.9 | 3.4 | 0 | 0 | 4.7 |
| Modified-T bait Station | 4 | setup | 0.3 | 0.9 | 0 | 0 | 0 | 1.2 |
| Underground bait Station | 4 | setup | 0.4 | 0.9 | 2.6 | 0 | 0 | 3.9 |

standard-T bait station compared to the modified-T, yet only 20% less from the underground than the standard-T in the choice test. When there was no standard-T bait station offered, such as in the video-taping study, and the observations of bait stations were made over a longer period of time, there was no difference in overall bait consumption between the modified-T bait and the underground bait station. The underground bait station gave satisfactory performance in this test.

Selection of bait station type is based on several factors including cost, ease of construction, non-target species risks, and potential of tampering by people or domestic and wild animals. Both the modified and the underground bait stations were difficult to service after rain events. Water collected in the arms of the modified-T and water drained into the underground bait stations, leading to bait spoilage. These stations could be difficult to maintain in irrigated areas because of this issue. Pocket gopher activity was observed around the underground bait stations, and black widow spiders were frequently observed on the underside of the irrigation-valve box cover. These factors should be considered when selecting the type of station used. In addition, 12 or more days may be necessary before bait stations are used.

While this study describes some differences in bait station use by ground squirrels, the experimental design makes detailed comparison difficult. It does not address the degree of bait station use by a population of squirrels. Our previous work suggests some squirrels may never use bait stations. However, we believe that this study does support these conclusions:

- 1) Squirrels will take some time before they enter and use bait stations. This could take 12 or more days.
- 2) Squirrels will become accustomed to bait stations and use them more rapidly if the station has been on-site.
- 3) Placing clean grain in a station may lead to faster acceptance of the station by squirrels.
- 4) Making the station harder to get into (such as the modified-T) may lead to increased time necessary for initial use and possibly less consumption overall.

ACKNOWLEDGEMENTS

Funding awarded by California Department of Agriculture Vertebrate Pest Research Advisory Committee. (CDFA Contract 04-0402). This project was conducted under UC Davis Animal Care and Use Committee protocol #11757, approved June 2, 2005. Special thanks to the Sunderland family of Valley Center, California for allowing us to use their farm as a research location.

LITERATURE CITED

- BIZNANOV, G., AND N. D. DOBROKHOTOVA. 2006. Experimental infection of ground squirrels (*Citellus pygmaeus* Pallas) with *Yersinia pestis* during hibernation. *J. Infection*. 54: 198-203.
- LONGHURST, W. M. 1957. A history of squirrel burrow gully formation in relation to grazing. *J. Range Manage.* 10:182-184.
- MARSH, R.E. 1978. Ground squirrels, a pest to almond growers. University of California Educational Handout, Pomology Short Course. 11 pp.
- MARSH, R. E. 1982. Ground squirrels, prairie dogs and marmots as pests on rangeland. Pp. 195-208 in: Proc., Organization and Practice of Vertebrate Pest Control, ICI Plant Protection Division, Hampshire, England.
- MARSH, R. E. 1994. Current (1994) ground squirrel control practices in California. *Proc. Vertebr. Pest Conf.* 16:61-65.
- MARSH, R. E. 1995. Instructions for making an underground rodent bait station. University of California educational handout. 3 pp.
- MARSH, R. E. 1998. Historical review of ground squirrel crop damage in California. *Int. Biodeter. Biodegrad.* 42:93-99.
- SALMON, T. P. 1981. Controlling ground squirrels around structures, gardens and small farms. Educational Leaflet 21179. Div. of Agricultural Sciences, University of California Cooperative Extension, Berkeley, CA. 11 pp.
- TASHEVA, M. 1995. Anticoagulant rodenticides. *Environmental Health Criteria*. 175. World Health Organization, Geneva, Switzerland. 109 pp.
- WARE, G. W. 2000. Rodenticides. Ch. 7 in: *The Pesticide Book*, 5th Ed. Thomson Publications, Fresno, CA.
- WHISSON, D. A. 1999. Modified bait stations for California ground squirrel control in endangered kangaroo rat habitat. *Wildl. Soc. Bull.* 27:172-177.